

# HORIZONTAL SURGE SYSTEM



**Lockwood  
Products**



## **DEAERATOR BYPASS OPTION**

*When the deaerator is down for maintenance, this option allows the surge tank to supply water directly to the boiler feed pumps through a suction manifold.*

Lockwood surge systems are packaged, atmospheric-pressure, storage tanks built for commercial or industrial steam systems. The storage tank blends makeup water and condensate returns before being pumped to the deaerator. The tank is elevated over the transfer pump(s) to provide sufficient NPSH for water temperatures up to 200°F. Vertical, multistage, centrifugal transfer pumps are typically utilized since they are common in the boiler room.

Systems can be fully customized to meet each customer's specific needs. Systems can be

as simple or complex as desired. The storage tank is typically made of stainless steel for increased life. Makeup water controls can be mechanical, float/probe type with solenoid valve, or modulating via an electronic control valve. Steam preheat packages can be utilized to elevate the water temperature before sending makeup water to the deaerator. Other typical trim items include: thermometer with separable well, gauge glass, anode, and pump suction piping with shutoff valve and strainer.

*Surge tanks provide a location to mix hot condensate and cold makeup water before it reaches the deaerator.*

*A surge tank is recommended when the condensate returns exceed 50%.*

**CUSTOM ENGINEERED SOLUTIONS TO COMPLEX PROBLEMS**

MODEL	SRG180	SRG250	SRG350	SRG500	SRG750
STORAGE (GAL)	180	250	350	500	750
CAPACITY (LBS/HR)	5000	10000	15000	20000	30000
STORAGE TANK DIAMETER (IN)	30	36	42	42	48
STORAGE TANK LENGTH (IN)	60	60	60	84	96
DIMENSION A (IN)	79	79	79	103	115
DIMENSION B (IN)	60	60	60	84	92
DIMENSION C (IN)	42	48	53	53	58
DIMENSION D (IN)	32	38	44	44	49
DIMENSION E (IN)	60	60	60	60	72
DIMENSION F (IN)	80	83	86	86	101
CONDENSATE RETURN (IN)	4	4	4	4	4
OVERFLOW (IN)	4	4	4	4	4
VENT LINE (IN)	(2) 2	(2) 2-1/2	(2) 3	(2) 3	(2) 3
DRAIN (IN)	1-1/2	1-1/2	1-1/2	1-1/2	2
TRANSFER PUMP HORSEPOWER	3/4	2	2	3	2
TRANSFER PUMP FLOWRATE (GPM)	13	25	35	48	74
SHIPPING WEIGHT (LBS)	800	1100	1400	1800	2200
OPERATING WEIGHT (LBS)	1625	2275	3000	4000	5450
FLOODED WEIGHT (LBS)	2200	3200	4325	5800	8250

**Larger models available.  
Contact Lockwood Sales  
for more information.**

**NOTES:**

- Typical trim and options shown on Surge System Option Flyer
- All dimensions and volumes are approximate and subject to change without notice
- Stand height shown is typical but can be adjusted as needed by application
- Weights include tank, stand and two pumps

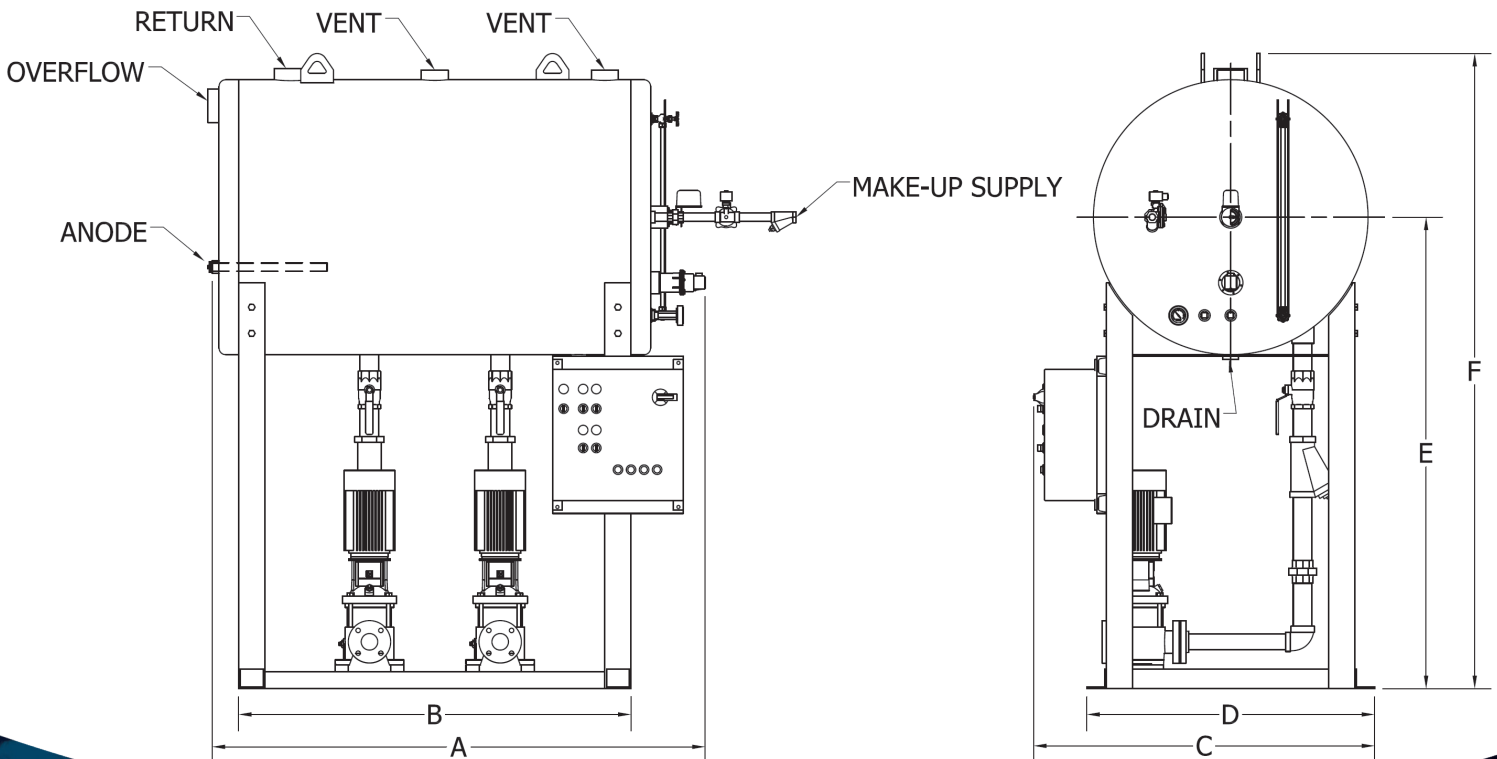

**Lockwood  
Products**

3010 Spring Industrial Drive, Powder Springs, GA 30127  
Main: (404) 505-2520 • Toll Free: (800) 365-1500  
www.lockwoodproducts.com • sales@lockwoodproducts.com



**QUALITY PRODUCTS & SUPPORT FOR YEARS TO COME**